

User Guide and Assembly Instructions

MADISON

FRONT VIEW

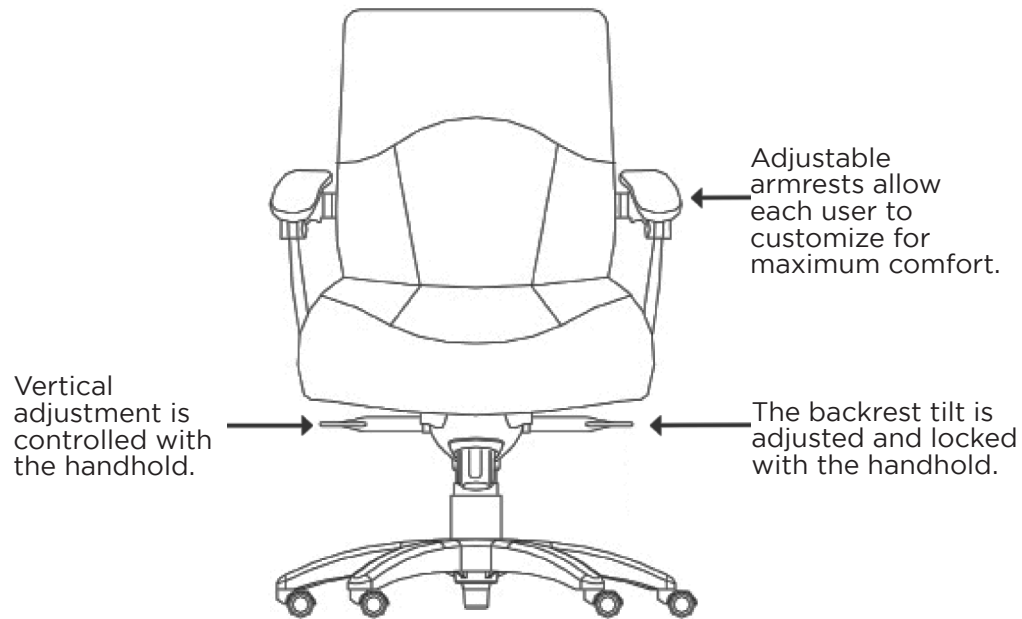

ADJUSTMENT KNOBS

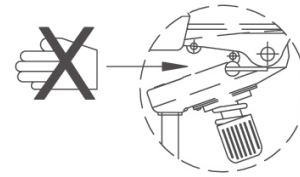

Adjustable tension knob for back tilt to maximize comfort for varying sized users.



Parts and Hardware

Attention: Carefully check all parts according to the instructions before assembling. Please assemble carefully to avoid scratching surfaces, especially powder coated surfaces.

Item	Parts	Qty.
A	Backrest	1
B	Armrest L/R	1 ea
C	Mechanism	1
D	Seat Cushion	1
E	Gas Lift	1
F	Base	1
G	Caster	5
H	Telescoping Cover	1

Hardware	Headrest Parts/ Hardware	Qty.
A	Screw 5/16" x 1-1/4"	2
B	Screw 5/16" x 1"	2
C	Screw 5/16" x 3/4"	3
D	Screw 5/16" x 7/8"	2
E	Screw 5/16" x 1-1/8"	2
F	Flat Washer	5
G	Spring Washer	5
H	Four-angle Washer	2
I	L Shape Wrench	1
J	T Shape Wrench	1
K	Inverse Cup	2
L	Big Cap	4
M	Small Cap L/R	1 ea

Chair Assembly Instructions

1. Attach the mechanism [C] to the seat cushion [D] to fasten with screws [A & B]. Screw [A] is for the front of the seat cushion and screw [B] is for the back of the seat cushion.
2. Attach caster [G] to the base [F]. Insert the gas lift [E] to the center hole of the 5 star base [F] and place telescoping cover [H] to the gas lift [E].
3. First add the gas lift [E] into the hole of the mechanism [C] that assembled in the seat cushion [D]. Then assemble the backrest [A] into the steel beneath the mechanism [C]. Insert screws.

Note: Do not tighten the screws until after assembling the arm rest.

Before fastening the screws, add the spring washer [G] and common washer [F] into the screw [C]. Make sure the steel shell of the backrest [A] and the steel mechanism [C] are at the same level.

4. Attach the armrest [B] to the chair, using instructions on the next page.

See next page for Armrest Assembly Guide.

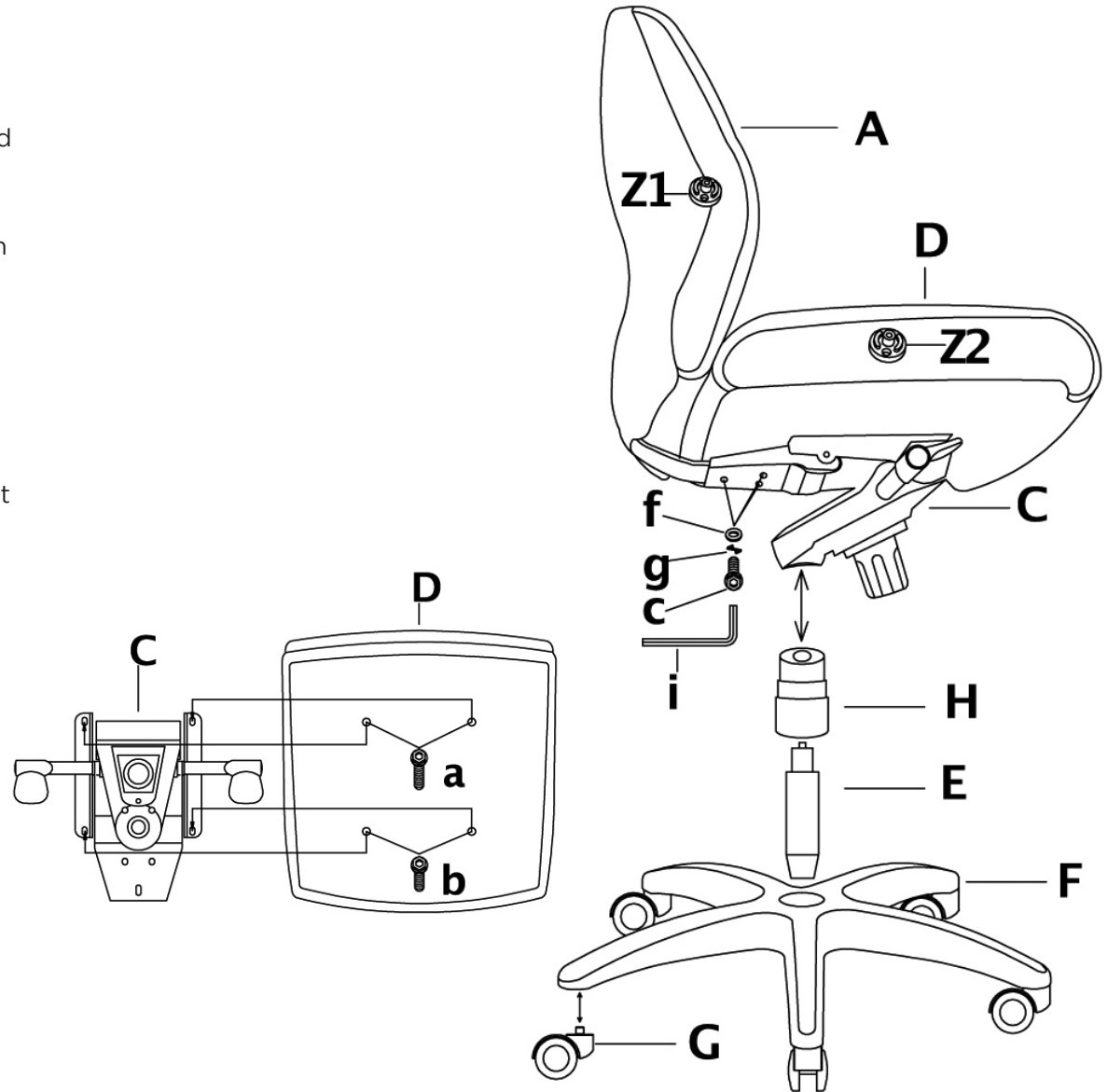

Product Dimensions

